

OWNER'S MANUAL

MITT MAX-T 125



Dear Customer:

Thank you for purchasing the vehicle.

The vehicle is a product manufactured by using advanced equipment and made up of high-quality component parts. Equipped with electronic igniter, electric starting motor and protection -welded frame, the vehicle features high performance, good fuel economy, low noise level, quick acceleration and good mobility. All these features combine to make the it a high-rating vehicle for use in urban areas as well as a trendy symbol of the modern world. This manual provides detailed information about the correct operation, maintenance and adjustment of the vehicle and following these tips can make your vehicle durable. The manufacturer hereby beg your understanding in case of any inconsistence between the content (pictures or verbal descriptions) of this manual and the actual condition of your vehicle due to possible changes in the specifications. Please read this manual carefully to ensure safety and maximum ease of use. We remain wishing you all the best with your vehicle.

Important Notice:

- **Driver and passenger**

This vehicle is designed to carry only one driver and one passenger. Do not exceed the rated load capacity specified on the specification label.

- **Road condition**

This vehicle is designed to travel on flat road.

- **Read this manual carefully to get a good understanding of the information contained there in.**

- **Pay special attention to sentences or paragraphs under the following headings:**

WARNING:

This heading warns you that serious personal injury or death may result if fail to operate as instructed in the manual.

CAUTION:

This heading reminds you that personal injury or mechanical damage may result if you fail to operate as instructed in the manual.

catalogue

1. Safe driving of motorcycles

The Safe Driving rules.....	5
Load.....	6

2. Location diagram and use instructions of each part

Location diagram of each part.....	7-8
Instrument and indicator light.....	9-12
Ignition switch.....	13-14
Steering lock.....	14
Seat lock.....	14
Handle switch.....	15-16

3. Operation guidance

Pre-driving inspection.....	17-18
Engine start.....	19
Driving the motorcycle.....	20
Driving operation.....	21-22
Engine shutdown operation.....	23
Parking operation.....	23

4. Maintenance and repair

Maintenance cycle schedule.....	24-26
Simple troubleshooting.....	27-29
Cleaning of the air filter.....	30
Maintenance of the storage battery.....	30
Oil replacement, oil filter cleaning.....	31-32
Gear box oil replacement.....	33
Spark plug.....	34
Fuse replacement.....	34

5. Vehicle storage

Storage.....	35-36
--------------	-------

6. Main technical data.....37-39

1. Safe driving of motorcycles

Safe driving rules

1. Many traffic accidents of motorcycles are caused by other vehicle drivers can not see the motorcycle driver. Therefore, motorcycle drivers should try to make other vehicle drivers can clearly see their own, such as: ※Put on the bright colored clothes.
※Avoid driving under light glare at night, blind sight corners, and unguarded conditions.
2. Drive very carefully at road intersections, the entrances and exits of the parking lot, and in the driveway.
3. Speeding is easy to cause accidents, should abide by the speed regulations, absolutely do not exceed the prescribed speed of driving.
4. Whoever just learned to drive a motorcycle, should be fully familiar with the performance of the motorcycle before they can drive on the road. Never lend a motorcycle to someone who has no license and little experience.
5. Avoid driving through rough roads, because the road surface may lead to operation failure or structural damage of the body.
6. Before driving a motorcycle, we must first do the inspection work before driving.
7. When driving, to hold the handlebars with both hands and pedal on the pedal position. Do not be too close to other motor vehicles, it is strictly prohibited to fight for the road, strictly abide by the local traffic laws and regulations.

Load

※ warn:

Storage facilities such as top case, can only put items with lighter weight.

The weight of the placed items shall not exceed the weight specified in Table 1.

Table 1

Storage item	weight
The top case	2kg
glove box	5kg

When calculating whether the load of the vehicle (up to 150 kg) is overloaded, the weight of the debris and goods contained in the vehicle and the weight of the driver and the passenger should be added together.

If the vehicle is overloaded, it will affect the stability and handling of the vehicle.

All the objects in the car should be fastened.

2. Location diagram and use instructions of each part

Location diagram of each part-Left view



1. rearview mirror 2. headlight 3. Front turn signal 4. fuel tank 5. Battery
6. Sit cushion 7. rear shelf 8. air filter 9. Main stand 10. Side stand

Location diagram of each part-right view



1. Throttle switch 2. Ignition switch 3. Muffler
4. taillight / brake light / rear license plate light 5. Rear turn signal

Instrumentation and indicator lights

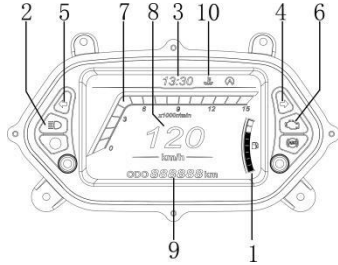

1. Fuel guage

The Fuel guage shows the amount of fuel in the fuel tank. As the fuel level decreases, the fuel label moves toward "E (empty)". When the fuel identification reaches the red area, the fuel surplus in the fuel tank is approximately 1.0L. If this happens, refuel as soon as possible.

2. High-beam indicator light

When the light switch button is in the "H" position, the high beam indicator is on.

3. Time display

4. Right-turn indicator light

The indicator light flashes when you push the turn signal switch to the right.

5. Left-turn indicator light

The indicator light flashes when pushing the turn signal switch to the left.

6. Fault lamp

After the faulty car starts, if the electric injection system fails, the fault lamp will light up. When each device of the electrical system fails, the fault can be removed through the fault code.

7. RPM

Display the real-time vehicle rotation speed.

8. Speedometer

Display the vehicle speed.

9. Mileometer

The short odometer shows the mileage after being set to zero, or to show the total distance traveled.

10. Water temperature fault lamp

The engine cooling system is abnormal; if the

antifreeze in the engine cooling system is missing, there may be leakage points in the engine; the water temperature indicator light is always on, indicating that the coolant temperature exceeds the specified value, and the driving should be suspended immediately.

Instrumentation and indicator lights

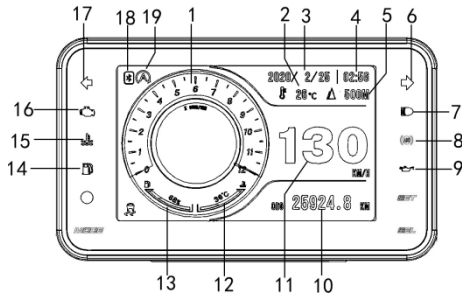

1. Tachometer: display the running speed of the vehicle when the vehicle is running.
2. Atmospheric temperature
3. Date display
4. Time display
5. The altitude
6. Right turn indicator: When the turn signal button moves to the right, the right turn indicator flashes.
7. High beam indicator: When the lighting switch button is in the "≡D" position, the high beam indicator is lit.

8. ABS: through the sensor installed on the wheel giving the dead signal, the controller command regulator reduce the oil pressure of the wheel brake cylinder, reduce the brake torque, after a certain time, then restore the original oil pressure, constantly this cycle (5~10 times per second), always make the wheel in rotation and has the maximum braking torque.

9. Oil warning lamp

10. The mileage display

11. speedometer: shows the vehicle speed

12. Water temperature indicator lamp

13. Oil volume display

14. Fuel warning lamp: the oil quantity is not enough. This light is on, please refuel in time.

15. Water temperature warning light: the water temperature is too high.

16. Fault light: After the vehicle starts, if the electric injection system is faulty, the fault light will be lit. When each device of the electrical system fails, the fault can be removed through the fault code. (See the



attached page for the troubleshooting method.)

17. Left turn indicator: When the turn signal button is pushed left, the left turn indicator flashes.

18. Bluetooth connection

19. Start-stop indicator

Ignition switch 1

- ①  position Turn the switch to this position to start the engine; the switch key can not be pulled out in this position.
- ②  position Turn the switch to this position to shut down the engine, the switch key can be pulled out in this position.
- ③ Steering lock

Turn the handlebars left, turn to the end, then press the ignition key to "🔒"

Position, the steering device can be locked: To open the steering lock, refer to the opposite procedure to the above.

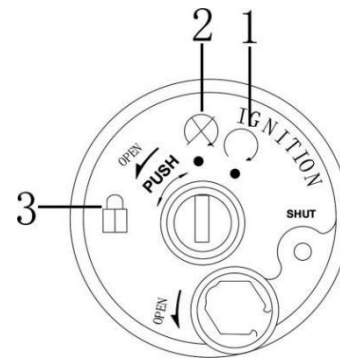

Seat lock

Insert the ignition key into the lock hole and rotate it anticlockwise to the "OPEN" position.

Ignition switch 2

① position Turn the switch to this position to start the engine ; the switch key can not be pulled out in this position.

② position Turn the switch to this position to shut down the engine, the switch key can be pulled out in this position.

③ Steering lock

Turn the handlebars left to the end, then press the ignition key to "I" 

Position, the steering device can be locked; To open the steering lock, refer to the opposite procedure to the above.

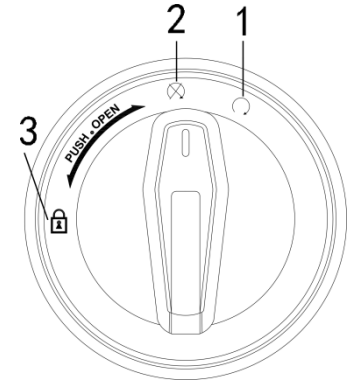

Seat lock

Insert the ignition key into the lock hole and rotate it anticlockwise to the "OPEN" position.

Handle switch

Left combination switch

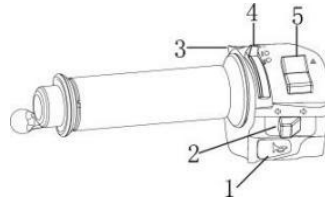

1 The horn switch "🔊"

Press this switch to make the horn sound.

2 Turn signal switch "↔"

Turn the switch to the right (↗) to display the right turn signal; Turn the switch to the left (↖) to display the left turn signal. To eliminate the signal, return the switch to the central position and press it down.

3 Passing switch (≡○)

Press this switch to light the high beam, release then light out, used to remind the opposite vehicle to pay attention or to switch to the near light, and to remind the front vehicle in the same direction to avoid for passing.

4 High beam and low beam switch "≡○/≡○"

≡○The high beam of the headlight is lit, ≡○and the low beam of the headlight is lit

5 Warning lamp (double flash) switch "⚠"

Turn the switch to "⚠" then the front and rear turn lights flash.

Right combination switch

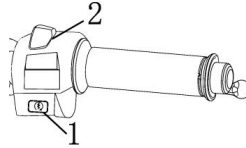

1 Start switch “”

To start the engine, press the start switch while holding either the front brake handle (front brake handle) or the rear brake handle (rear brake handle).

2 Start and stop switch



The start-stop function is turned off.



The start-stop function is turned on.

Note:

The vehicle has automatic start-stop function and side stand stalling function. Before driving, we must understand the automatic start and stop function in detail: the engine temperature reaches 65°C, the speed reaches 15km / h, then the start- stop function opens and the indicator light on on instrument. When the speed drops to 0 km/h, the vehicle automatically stalls in 3 seconds. Pull the throttle gently to start automatically. This function can be turned off on the right hand switch.

III. Operation guide

Pre-driving inspection

Routine inspection should be carried out to ensure that the performance is good and achieves safe driving results.

Fuel tank capacity

Turn on the ignition switch and watch the fuel gauge. When it is close to the red mark, refuel.

At the same time, check the fuel tank for oil leakage.

- Fuel tank capacity: 11 liters
- Insert the key into the key hole of the fuel tank cap and twist it clockwise to open it.
- Unleaded gasoline with an octane number of 92 or above should be used as much as possible.
- Be careful not to bring dust, moisture or other contaminants into the tank when refueling.



Warning:

- **Gasoline is a very flammable substance and can catch fire or even explode under certain conditions. Therefore, when refueling, do it in a well-ventilated area and turn off the engine first. Fireworks are prohibited in areas where fuel is refueled and stored.**
- **When refueling, do not overfill the fuel tank (no oil should accumulate in the fuel tank inlet pipe). After adding fuel, be sure to lock the fuel tank lock.**
- **Gasoline is toxic and can cause fainting if swallowed accidentally. Therefore, do not allow prolonged skin contact with gasoline. Never let children come into contact with gasoline. If you swallow gasoline, seek medical attention immediately.**

Inspection of engine oil level

Check engine oil level

1. Use a parking stand to support the motorcycle on a flat ground, unscrew the oil dipstick, wipe it clean with a rag, then insert the oil dipstick back in (do not screw it in), then pull it out to check for oil stains.
2. If the engine oil level is close to the lower limit mark 2 on the oil dipstick, you should add engine oil that meets the standard. The amount of oil should not exceed the upper limit mark 3. After burning, re-insert the oil dipstick, tighten it, and check whether there is any leakage. oil phenomenon.

Recommended engine oil grades

SL 10W-40 (crankcase)

tire

In order to maximize the performance of your vehicle, as well as its durability and safe operation, you should pay attention to the following points for the specified tires.

Tire pressure

Before each ride, tire pressure should be checked and adjusted if necessary.



- **Checking and adjusting tire pressure must be done when the tires are cool (that is, the tire temperature is the**

same as the ambient temperature).

- The tire pressure must be adjusted according to the driving speed and the total weight of the driver, passengers, cargo and accessories allowed for this vehicle.

Start the engine

1. Insert the key into the ignition switch and turn it to the "O" position.
2. Hold the brake handle, press the start button 1 at the same time, and turn the accelerator slightly to start the engine. Each electric start time is no more than 5 seconds.

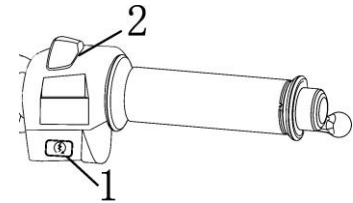

Warning _____

- Before riding a motorcycle, make sure the single support is in place, otherwise serious accidents may result when turning.
- When electric starting fails, stop for 30 seconds before electric starting.
- When starting from cold, the engine should be warmed up briefly (about 3 minutes) after starting before turning to driving.
- In extremely hot weather conditions, if the engine is left running at idling speed for a long time, the engine will overheat and the engine should be shut down in time.

driving a motorcycle

Warning

- During the driving the scooter, the muffler temperature will be high. If you accidentally touch it, you will be burned. Even in a short time after the engine is turned off, the temperature is enough to cause burns. Therefore, when driving Wear long trousers to protect yourself to avoid that.
- Wear protective equipment such as helmets, dust glasses, and gloves while driving.
- It is not advisable to wear loose or ill-fitting clothing when driving, otherwise loose sleeves or trouser legs may catch on brake handles, braces, etc., causing safety accidents.
- All equipments installed on the scooter must comply with local traffic laws and regulationse. Bring all necessary documents in accordance with the requirements and regulations before driving.

Note: The speed and load of a new motorcycle must be controlled within 1,000km during the running-in period; the load should be within 100kg (including the driver). Over-speeding and overloading during the running-in period will greatly shorten the engine life. The crankcase oil must be replaced after runs in for 300km.

speed according to table 2

range (km)	0~200	200~500	500~1000
speed(km/h)	≤30	≤45	≤55

driving operation

- Keep back side stand and sit on the seat, put your left foot on the ground to make scooter vertical to the ground.
- Slowly increase the accelerator to start the scooter, then retract the left foot to control the accelerator to reach the appropriate speed. When decelerating, gradually close the throttle.



Warning

- Do not operate the throttle quickly, otherwise, the motorcycle will rush forward quickly and may lose control.
- Before driving the scooter, be sure to retract the pole and carefully observe the road conditions along the route of the vehicle.

brake operation

1. Control the throttle

When reducing the speed of a motorcycle, it is very important to reduce the opening of the accelerator and cooperate with the operation of the front and rear brakes.



Warning

- Special care must be taken when braking, accelerating or steering when driving on wet or soft roads or in rainy conditions.

1. Simultaneous operation of front and rear brakes

Note: When driving down a steep slope, you should first completely close the accelerator and use the front and rear brakes to reduce the vehicle speed. Continuous operation of the brake should be avoided, otherwise it will overheat the brake and reduce the braking performance of the brake.

When driving at medium or high speed, especially the road is slippery, do not use the front or rear brakes alone. Use the rear brake first, and then use the front brake together to avoid accidents caused by side slip.

engine shutdown operation

- • Close the throttle: rotate to the final position in the direction shown (under normal circumstances, release the throttle handle and the engine will be at idle speed)
- • Turn the ignition switch key to the OFF (~~ON~~) position.

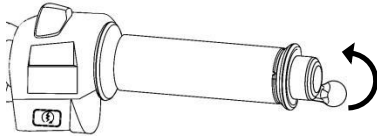

parking operation

When parking, turn the ignition switch to the off (~~ON~~) position, set up the parking rack, and lock the handlebars.

Warning: Motorcycles should be parked on hard and flat ground, otherwise, personal injury or vehicle tipping may occur.

Key points for preventing theft:

- • Lock the handlebars promptly and never leave the car key in the keyhole of the ignition switch.
- • Wherever possible, it is best to park your car in a locked garage.

IV. Maintenance and repair

Maintenance cycle schedule

The maintenance cycle is the maintenance period based on the driving mileage, which is the basis for the guidance of regular maintenance and lubrication of the vehicle. If the motorcycle is driven at high speed under harsh conditions for a long time, the frequency of maintenance must be increased. If the motorcycle has been overhauled or has been in a collision, the maintenance department personnel must carefully check the main components of the motorcycle, such as the frame, hangers, driving steering components, repair or replace parts that have been misaligned or damaged to ensure safe driving.

Note: In order to ensure the safety and reliability of the motorcycle, it is not allowed to adjust the ECU air-fuel ratio at will. When replacing the exhaust muffler, throttle valve body and carbon canister, you must use our company's original parts of the same model, otherwise it will affect the performance of the entire vehicle. Emissions performance. When repairing or maintaining other parts, try to replace them with new original parts of the company or similar parts of equal quality. If other lower quality parts are used, the performance and operating functionality of the motorcycle will be affected.

Warning: To ensure the safety of personnel and avoid injury, regardless of any maintenance work, be sure to turn off the engine first, park the vehicle on a flat and hard surface and support it firmly.

※Note: If you park your car for more than a month or stop using it during winter, you need to do maintenance work first to prevent deterioration and corrosion of fuel, tires, batteries, etc.

Maintenance cycle schedule

* Unless the driver or the owner has a complete set of repair tools and maintenance information and is a qualified mechanic, professionals should be hired to perform maintenance and repairs.

**For safety reasons, we advocate that these items should be maintained or repaired by maintenance department personnel.

Note: 1. If driving in a particularly humid or dusty area. It is best to shorten the specified maintenance period, and it must be replaced when fuel consumption increases and acceleration becomes weak.

2. When you often drive on uneven roads, you must maintain the vehicle in order to maintain its performance.

3. Replace seasonally in severe cold areas.

I: It needs to be checked and adjusted when necessary C: It needs to be cleaned R: it needs to be replaced

Cycle		Running-in period		Odometer reading (×1000km)				
				1	4	8	12	
1	Fuel pipe			I	I	I	I	
2	Throttle operation			I	I	I	I	
3	Air filter element		(Note1)	Every 1000km C, R when necessary				
4	Spark plug			Every 2000km C, R when necessary				
5	Valve clearance			I	I	I	I	
6	Engine oil		(300km)R	R	(every 3000km)R			
7	Oil filter			C when changing the oil, R when				
8	Transmission belt			every 1000km I, if necessary R				
9	Gear box oil	(Note3)	(300km)R			I		
10	Braking system			I	I	I	I	
11	Brake switch				I	I	I	

Cycle		Running-in period		Odometer reading (×1000km)				
				1	4	8	12	
Item								
12	Headlight				I	I	I	
13	Suspension system				I	I	I	
14	Nuts and bolts tightening	(Note2)		I		I		
15	wheels, tires				I	I	I	
16	steering bearing			I			I	

Note: _____

● Hydraulic brake (brake) repair

- Regularly check and, if necessary, correct the brake (brake) fluid level.
- Replace the internal components of the brake (brake) master cylinder and caliper brake (brake) every two years, and replace the brake (brake) fluid.
- Replace brake (brake) hoses every four years and when ruptured or damaged.

troubleshooting

Fault	Fault cause		Troubleshooting
Engine can not start	Spark plug without spark	Spark plug damage	replace
		Damaged ignition coil	replace
		Damaged ignition switch	replace
		Ignition system detachment or looseness	Connect or tighten
	Spark plug with weak spark	Spark plug gap too small or too large	adjust
		Spark plug electrode ablation	replace
		Severe carbon accumulation in spark plugs	clean up
		Refer to Spark Plug No Spark	
	No mixture in the	Fuel tank running out of fuel	Refueling
		Oil pump plug-in loose	inspect
Oil pump not working		replace	

	cylinder	Blocked oil circuit	Unblock
		Air filter blockage	Clean the filter element
		Air leakage in the intake system	Check and eliminate
	Low cylinder compression force	Spark plug seat leakage	Tighten the spark plug
		Air leakage at the joint surface of the cylinder head	Replace gasket
		Worn valve seat ring	grind
		Severe wear of piston rings or cylinder	Replace the piston ring or cylinder
		The piston ring is broken or blocked by carbon deposition	Replace piston rings or clean carbon deposits

Fault	Fault cause	Troubleshooting
Power weakness and poor acceleration	Low fuel octane number	Replace fuel
	Blocked oil circuit, poor fuel supply	Clean the oil circuit
	Ignition time too early or too late	Check the triggering coil
	Spark too weak or disconnected	Check the ignition system and
	The mixture is too rich or too lean	Clean the throttle valve body
	Engine leakage	Check and eliminate
	Muffler blockage	Unblock
	Belt worn out	replace
	Automatic clutch roller worn out	replace
	Refer to <Engine can not start>	
	Damaged starting relay	replace
Low battery level	charging	
driving is unstable	Excessive steering bearing clearance	adjust
	Insufficient tire pressure	Add to the specified air
	front and rear wheel axles Loose	Tighten the nut
brake failure	Brake shoe worn out to limit	replace
	Brake cam worn out	replace
	Excessive free travel	Adjust and check the hydraulic

Cleaning of the air filter

- Remove the fixing screws of the air filter cover.
- Remove the filter element from the air filter box.
- Clean the filter element with compressed air or a dry brush, or place a new filter element in the filter box.

Follow the reverse procedure above to reinstall the air filter.

Warning:

- **Never use gasoline or low ignition point solvents to clean paper filter.**

Battery maintenance

This scooter adopts a sealed battery (without adding water)

Attention: The upper cover of the sealed battery electrolyte should never be opened.

- When corrosion occurs at the head of the battery pile, please remove the battery and remove it. (Rinse with boiling water)

Attention: When removing the battery, the ignition switch should be turned off, and then the negative pole should be removed first.

Remove the positive pole again, and install the positive pole before the negative pole during installation.

Oil replacement and cleaning of the oil filter

Oil replacement

- When changing the engine oil, it should be done under reliable conditions supported by a parking rack before the engine temperature has cooled down
- Heating engine.
- Turn off the engine and remove the oil drain bolt.
- Remove the oil drain bolt [3] and washer [2], and drain the oil.
- After completely draining the engine oil, install the oil drain bolt and replace it with a new gasket.
- Tighten the oil drain bolt to the specified torque.
- Torque: 25~30N·m
- Fill the crankcase with the specified engine oil.
- Oil capacity:
- After engine maintenance or major repair: add 0.8L
- Check the oil level and ensure that there is no oil leakage.

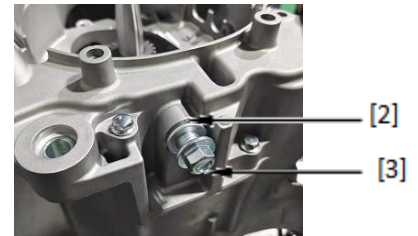
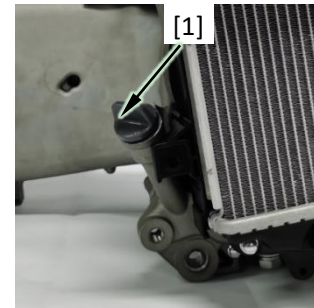

Cleaning of the Oil Filter strainer

- First, remove the oil dipstick and the oil filter cover 1, spring 2, and oil filter strainer 3
- Clean the filter strainer with solvent.
- Install the filter strainer, spring, and oil filter cover
- Fill the engine with oil that meets the specifications, and the amount of oil based on the upper limit mark on the oil dipstick.

When measuring the oil level, the oil dipstick cannot be screwed in

- Tighten the oil dipstick
- Start the engine, let it idle for a few minutes, and then stop the engine
- Remeasure the oil level, ensuring that the oil level is close to the upper limit mark, and there must be no oil leakage.

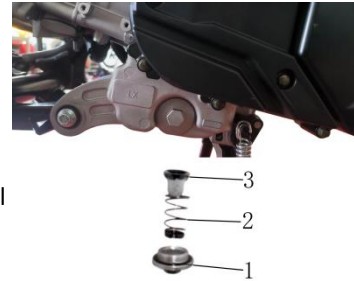

Replacement of gearbox oil

Suggested gear oil grade

SAE 80W/90 (Antifreeze oil can be used in cold regions)

Refueling capacity

Capacity during replacement: 0.15 liters

- Support the motorcycle with a parking stand
- Remove the oil injection bolt 1 and the oil drain bolt 2

Attention: When draining oil, the engine should have a certain temperature, and the motorcycle should be supported reliably by a parking rack. Ensure that the oil can be completely and quickly drained.

- Wipe the oil drain bolt clean before reinstalling and tightening it
- Slowly inject gear oil into the oil injection bolt hole using a syringe until gear oil begins to overflow from the oil injection bolt hole. Then install the oil injection bolts and tighten them.

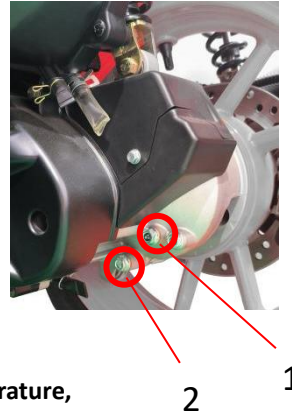

spark plug

Standard:: **CPR8EA-9 (NGK)**

- Disconnect the spark plug cap and use a special wrench to remove the spark plug.
- Check the electrodes on the spark plug and the ceramic head in the center for any buildup, erosion, or carbon deposits. If the phenomenon of corrosion is severe, the spark plug should be replaced.

Use spark plug cleaner to clean carbon and scale deposits, or use a brush to clean them.

- Adjust the gap between side electrode 1 and central electrode 2 to be controlled within (0.8-1.0) mm
- Do not use spark plugs of different grades than specified.

Replacement of fuses

The rated current of the main fuse is 15A/25A, located inside the battery box.

If the fuse frequently burns out, it indicates that there maybe a short circuit or overload in system. You should check with Local authorized maintenance shop. It is strictly prohibited to replace the specified fuse with copper wire.

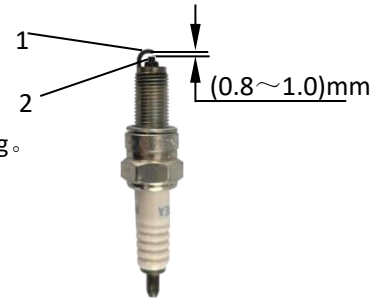

5、 scooter storage

Storage

When storing motorcycles for a long time, such as in winter, several steps need to be taken to prevent the failure or deterioration of the components caused by long-term non use of the motorcycle. In addition, some maintenance work needs to be carried out before preparing for storage, otherwise, once the motorcycle is used again, it is often forgotten to carry out this maintenance work.

- Change engine oil
- Drain all the stored oil in the fuel tank

Warning: Under certain conditions, gasoline is an object that can burn or explode. Therefore, it is strictly prohibited to use fireworks during fuel discharge

- Firstly, remove the spark plug and inject a tablespoon (15ml~20ml) of engine oil into the cylinder. Then, step on the engine starting rod several times to distribute the oil to each part, and then install the spark plug.
- Remove the battery and store it in a place that cannot freeze or be directly exposed to sunlight. The battery should be charged once a month.
- Wash the scooter thoroughly before wiping it dry. Apply wax to all paint surfaces and apply a layer of rust proof oil to other metal parts.
- cover the scooter (plastic cloth or other materials coated with glue are not allowed) and store it in a cool and dry place. The temperature change should not be significant every day, and it is absolutely not allowed to park in direct sunlight

When removing the scooter from the storage room and reusing it

- Remove the scooter cover and wipe the scooter clean. If the storage time has exceeded 4 months, the engine oil should be replaced.
- If necessary, charge it immediately and then install the battery.
- Conduct a pre driving inspection of all items (refer to pages 10 and 11), and test ride the scooter at low speed for a period of time in areas with less busy traffic to ensure safety.

6、 Main technical data

item	Parameters	project	Parameters
Length×Width×Height(mm)	1950×780×1130 (Short windshield+rear armrest)	Ignition method	ECU
	2050×780×1130 (Short windshield+rear shelf)	Starting method	Electric start
	1950×780×1310 (Long windshield+rear armrest)	Fuses	15 A/25A
	2050×780×1310 (Long windshield+rear shelf)	fuel consumption	2.4L/100Km
Wheelbase(mm)	1360	Climbing angle	≥16
Front wheel	130/60-13	battery	12V 8.6Ah
Rear wheel	130/60-13	Fuel grade	RQ92 以上
Ground clearance(mm)	95	Spark plug	CPR8EA-9(NGK)
curb weight(kg)	131	Spark plug gap mm	0.8~1.0
maximum load(kg)	150	Gasoline volume L	11.0
Handle rotation angle	≤48	Max speed(km/h)	95km/h-(125CC) 99km/h-(150CC)

Light parameters

OUIJA brand	parameters	QIMAN brand	parameters
Headlight (high beam)	LEDs × 4 12V 12W	Headlight (high beam)	LEDs × 4 12V 12W
Headlight (low beam)	LEDs × 2 12V 5W	Headlight (low beam)	LEDs × 2 12V 6W
Front position light	LEDs × 12 12V 1.6W	Front position light	LEDs × 30 12V 3.0W
Front turn signal	RY10W 12V 10W	Front turn signal	RY10W 12V 10W
Rear position light	LEDs × 42 12V 0.6W	Rear position light	LEDs × 27 12V 3.0W
Brake light	LEDs × 42 12V 3W	Brake light	LEDs × 43 12V 5.3W
Rear license plate light	LEDs × 3 12V 0.9W	Rear license plate light	LEDs × 3 12V 0.6W

LONCIN KS125C

engine type	1P52MI, Single cylinder, four stroke, water-cooled	Lubrication method	Combined of pressure and pressure splashing
Transmission type	CVT	Crankcase lubricating oil volume(L)	0.8
Transmission ratio	0.736~2.147	Lubricating oil grade	SL 10W-40 (crankcase)
diameter×Stroke (mm)	52.4×57.9	Gearbox oil volume(L)	0.15
Volume (ml)	124.9	Gear oil grade	SAE 80W/90
maximum power	8.5kW/8000 min ⁻¹	Idle speed r/min	1800±100 min ⁻¹
Maximum torque	12Nm/6000 min ⁻¹	Compression ratio	11:1

LONCIN KS150C

engine type	157MJ-J, Single cylinder, four stroke, water-cooled	Lubrication method	Combined of pressure and pressure splashing
Transmission type	CVT	Crankcase lubricating oil volume(L)	0.8
Transmission ratio	0.736~2.147	Lubricating oil grade	SL 10W-40 (crankcase)
diameter×Stroke (mm)	57.3×58	Gearbox oil volume(L)	0.15
Volume (ml)	149.6	Gear oil grade	SAE 80W/90
maximum power	10.5kW/8000 min ⁻¹	Idle speed r/min	1800±100 min ⁻¹
Maximum torque	14.5Nm/5000 min ⁻¹	Compression ratio	10.6:1